

The Advantages of Star Mixers Compared to Quad Diode Rings for the Realisation of Double Balanced Microwave Mixers

Andy Dearn and Liam Devlin

PRFI Ltd., Plextek House, London Road, Great Chesterford, Saffron Walden, CB10 1NY, UK;
(andy.dearn@prfi.com)

Abstract

Most commercially available, high linearity double balanced mixers adopt a quad diode ring topology. This is an excellent choice with many performance advantages. However, a star topology is functionally equivalent but offers a significant advantage in having inherently lower IF parasitics. This allows the realisation of mixers with much wider IF bandwidth, extending up into the RF and LO frequency bands. This paper describes the realisation of typical quad ring diode mixers and presents a practical example designed by PRFI. It then compares the achievable performance of a quad ring mixer to a star mixer, realised on the same process and targeting the same operating band.

Introduction

At Microwave and mmWave frequencies the most common form of a double-balanced diode-based mixer is the Quad Ring Mixer (QRM). This circuit consists of a ring of four diodes and two transformers, as shown in its simplest form in Figure 1 [1]. One of the transformers needs to be centre-tapped to allow extraction (or input, in upconvert) of the Intermediate frequency (IF). With practical Monolithic Integrated Circuit implementations, magnetics based or wire-wound transformers cannot be used. The transformers are typically replaced by planar transformer baluns [2]. The Star mixer differs from the QRM in that the four diodes are utilised in a star or cross configuration as shown in Figure 2. Two baluns are still required for the input of the Local Oscillator (LO) and the input (or output) of the RF signal. The main difference is that the common point of the star is a perfect virtual earth to both the LO and RF frequencies. This means the IF can be extracted directly from this point [3].

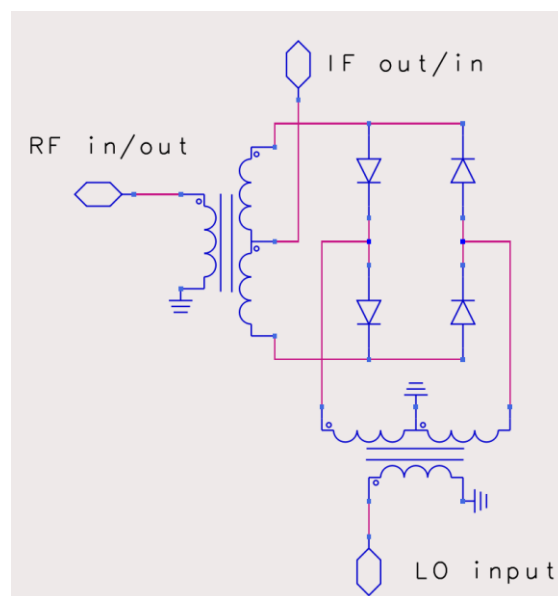

Figure 1: A double-balanced, diode based, quad ring mixer

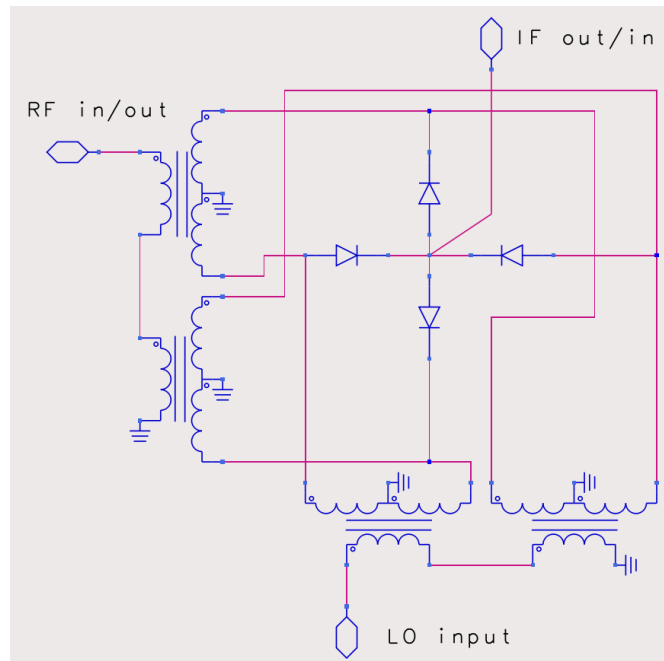

Figure 2: Star mixer configuration

Circuit Design

Quad Ring Mixer

A photograph of an example QRM MMIC design from PRFI is shown in Figure 3 [4]. Here the baluns are planar transformer designs based on the Marchand Balun. The concept of the Marchand Balun is shown in its simplest form in Figure 4. Each of the four transmission lines are $\lambda/4$ in length at the centre frequency of operation [5]. A more complex form, better suited to monolithic realisation, is shown in Figure 5. In this case the secondary 'winding' is formed of two coupled lines. A centre-tapped version of the Marchand Balun can be formed by AC coupling the secondary ground to form a convenient tap-off point, as shown in Figure 6. The conventional Marchand Balun and the centre-tapped version can be wrapped into planar transformer versions as shown in Figure 7 [6]. This was the approach used for the mixer in Figure 3.

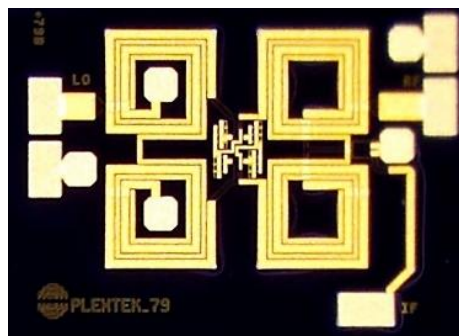

Figure 3: MMIC QRM example

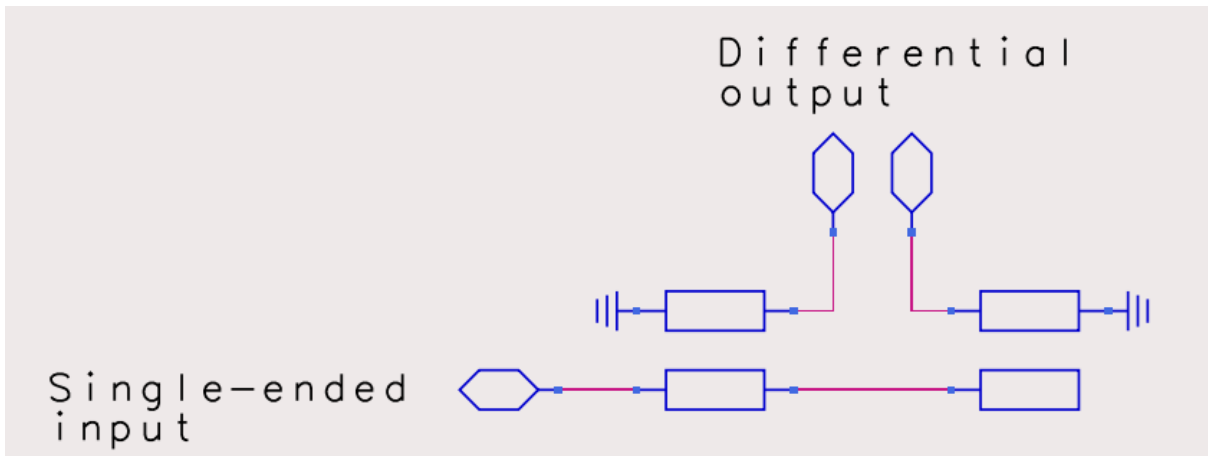

Figure 4: Simple Marchand balun

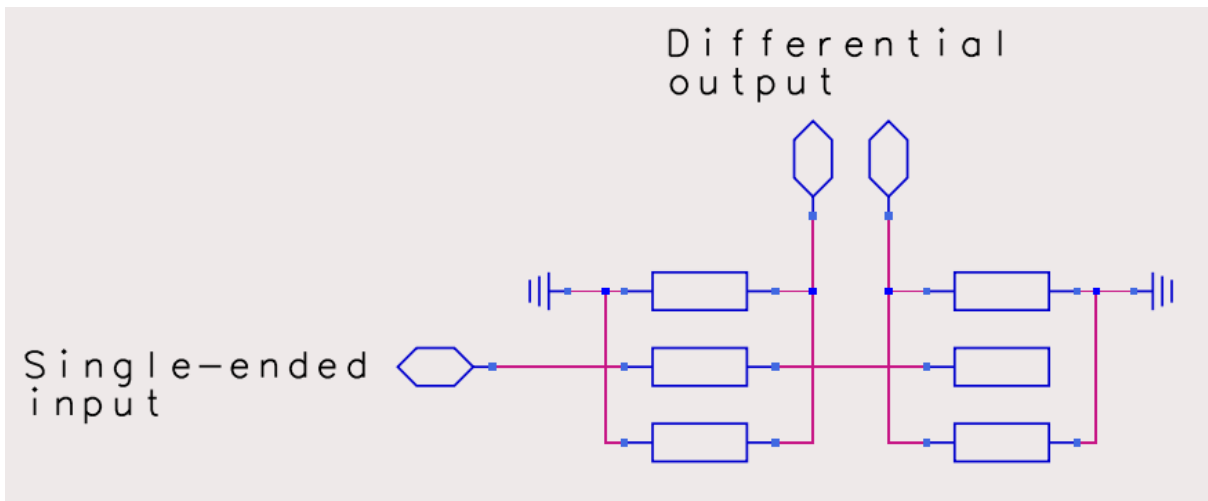

Figure 5: Three-line Marchand balun

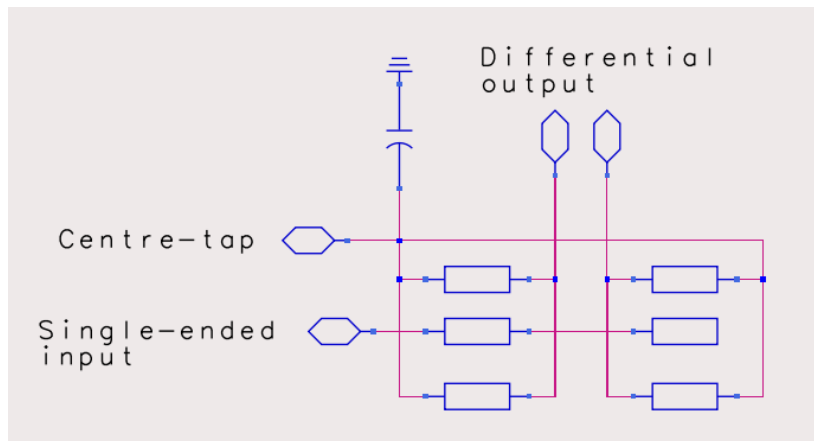
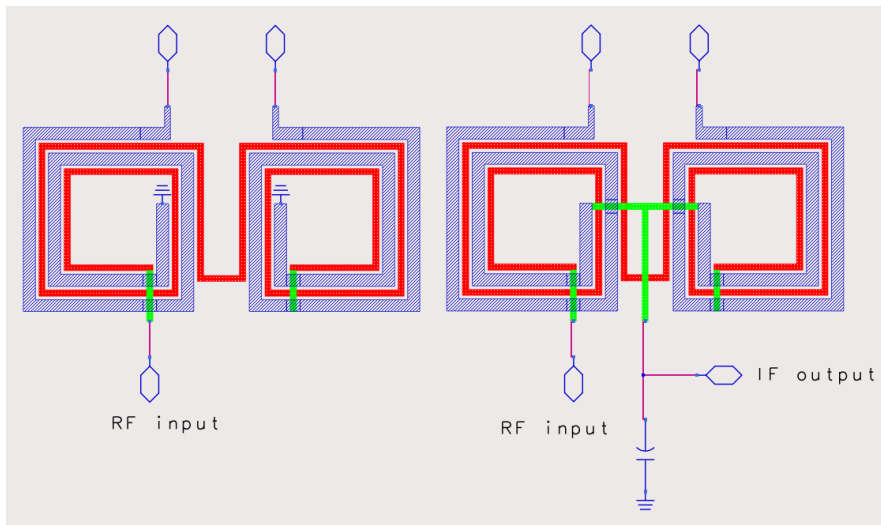

Figure 6: Centre-tapped version of the planar Marchand balun



**Figure 7: Planar transformer versions of the Marchand balun:
(a) 3-port; (b) centre-tapped**

Thus, the simplified schematic for the QRM using Planar Marchand baluns is given in Figure 8.

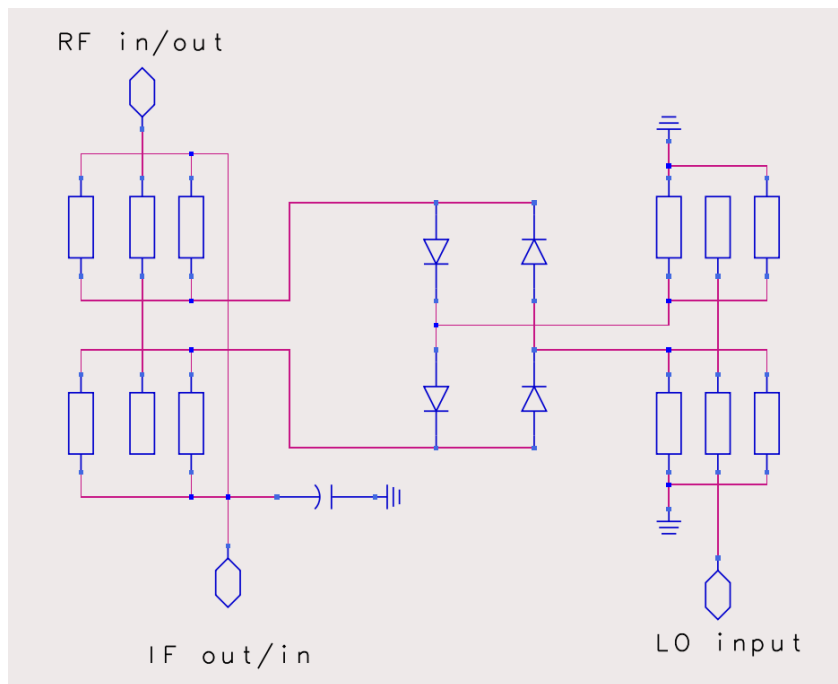

Figure 8: Schematic of QRM using Marchand baluns

Star Mixer

At first glance the transformer arrangement of the Star mixer shown in Figure 2 can appear daunting compared to that of the more conventional QRM. In reality there is an elegant solution in that two crossed Marchand baluns can be used [7]. This is illustrated in Figure 9

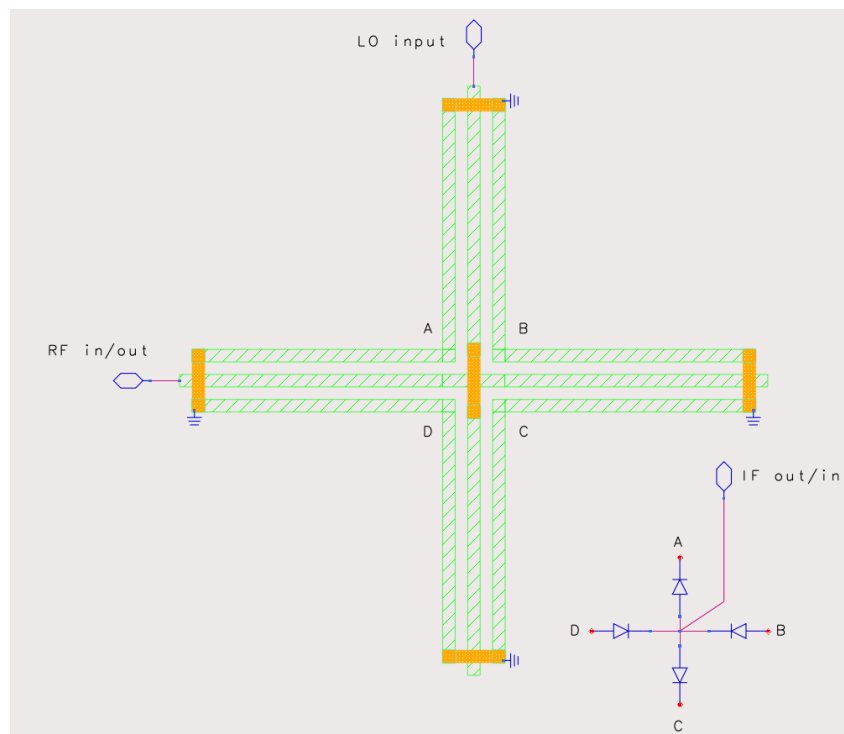

Figure 9: Practical MMIC implementation of the Star mixer using two Crossed Marchand baluns

Comparison of the QRM and Star Mixer

The two MMIC mixer designs were compared using the Harmonic Balance simulator within Keysight ADS. A commercially available GaAs HBT process from WIN Semiconductor was used, with Schottky diodes being used for the mixer elements. For the QRM mixer a planar Marchand balun and a centre-tapped version were adopted. The designs covered an approximate RF range of 6 to 20GHz. For the Star Mixer, two standard 3-line Marchand baluns were EM simulated in the crossed configuration of Figure 9. The nominal design range of the crossed Marchand baluns was again 6 to 20GHz. The same size diodes were used in both designs.

Several important mixer parameters were then analysed and compared. In all the following plots the Star mixer result is shown in **RED** and the QRM in **BLUE**. The first comparison (shown in Figure 10) is conversion gain vs. RF input frequency in Downconvert mode. In this particular simulation the LO input power is +15dBm and the IF output is fixed at 30MHz. It is clear from this plot that the QRM performs well over the full range of the baluns, i.e., 6 to 20GHz. The Star mixer, however, has a slightly reduced frequency range operating well across about an octave bandwidth. However, an important performance metric to note is that over the 9 to 17GHz band the Star mixer has approximately 2dB less conversion loss than the QRM.

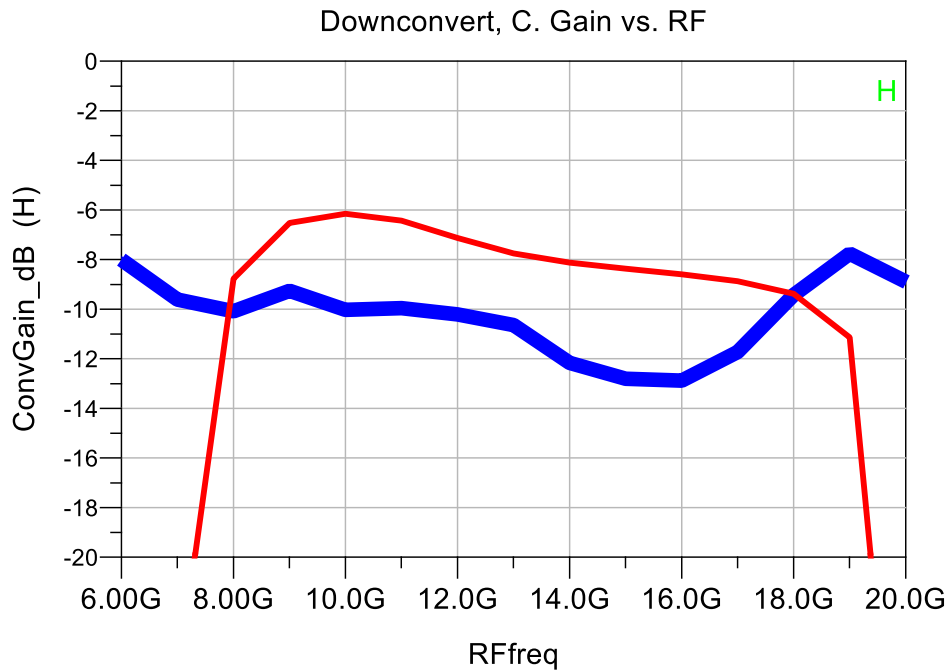

Figure 10: Comparison of conversion gain with RF input frequency

When comparing the conversion loss against IF (output) frequency the major advantage of the Star mixer configuration is revealed. Figure 11 shows conversion gain vs. IF output frequency. In this case the LO is fixed at 8GHz (+15dBm), and the varying RF input frequency is LO+IF. The practical maximum IF in the QRM case is of the order of 6GHz, which is at the bottom end of the RF and LO bands. The Star mixer consistently has 2dB less loss over this range, but also continues operating up to around 11GHz well into the RF and LO operating bands.

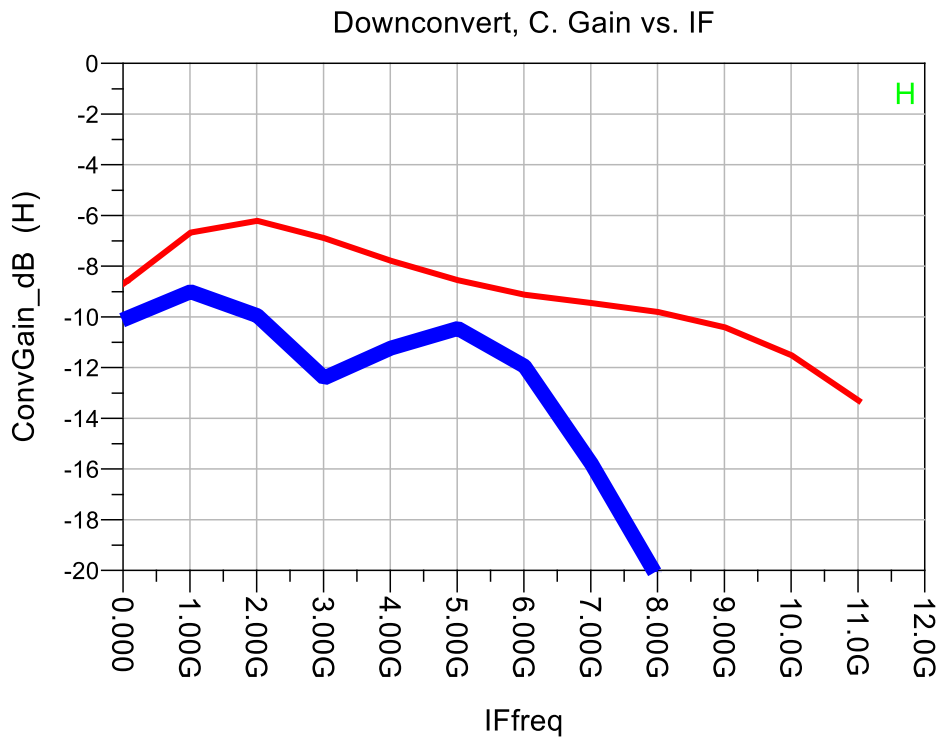

Figure 11: Comparison of Conversion Gain with IF output frequency:

Next, the power compression performance of the two mixers is considered. Figure 12 compares the 1dB compression point of the two mixers. Note, the input referred compression point is plotted, which is the commonly specified parameter for passive mixers, or indeed, any component with loss. At the two extremes of the Star mixer's band (9 and 18GHz) the values are roughly equal. In band the QRM is consistently 2dB higher. This is mainly due to the 2dB extra conversion loss of the QRM. The output referred 1dB compression point is actually higher in the Star mixer by 1 to 2 dB. Figure 13 compares the linearity of the two mixers in the form of the input referred third order intercept point (IIP3). Here the two mixer types offer comparable performance although because of its lower conversion loss the star mixer would offer higher output referred IP3.

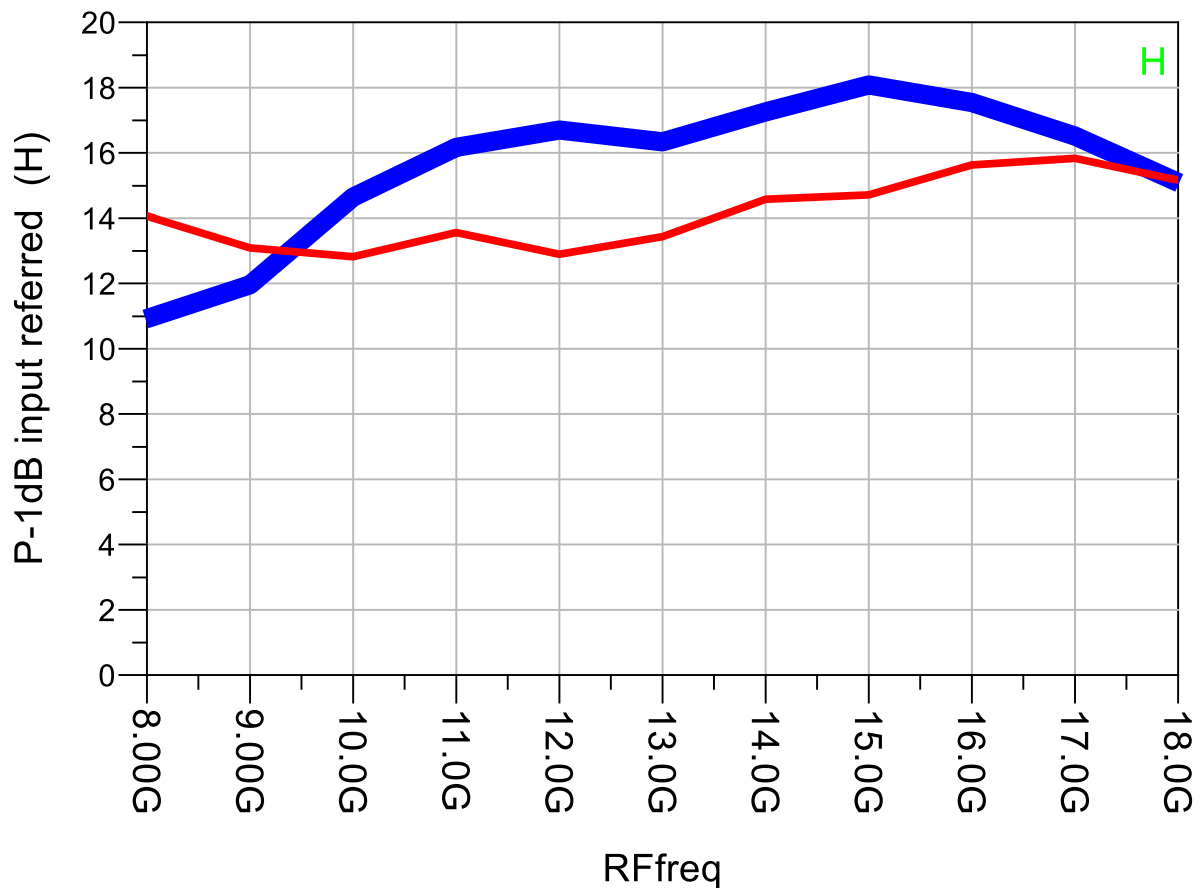

Figure 12: Comparison of P-1dB (input referred) with RF input frequency

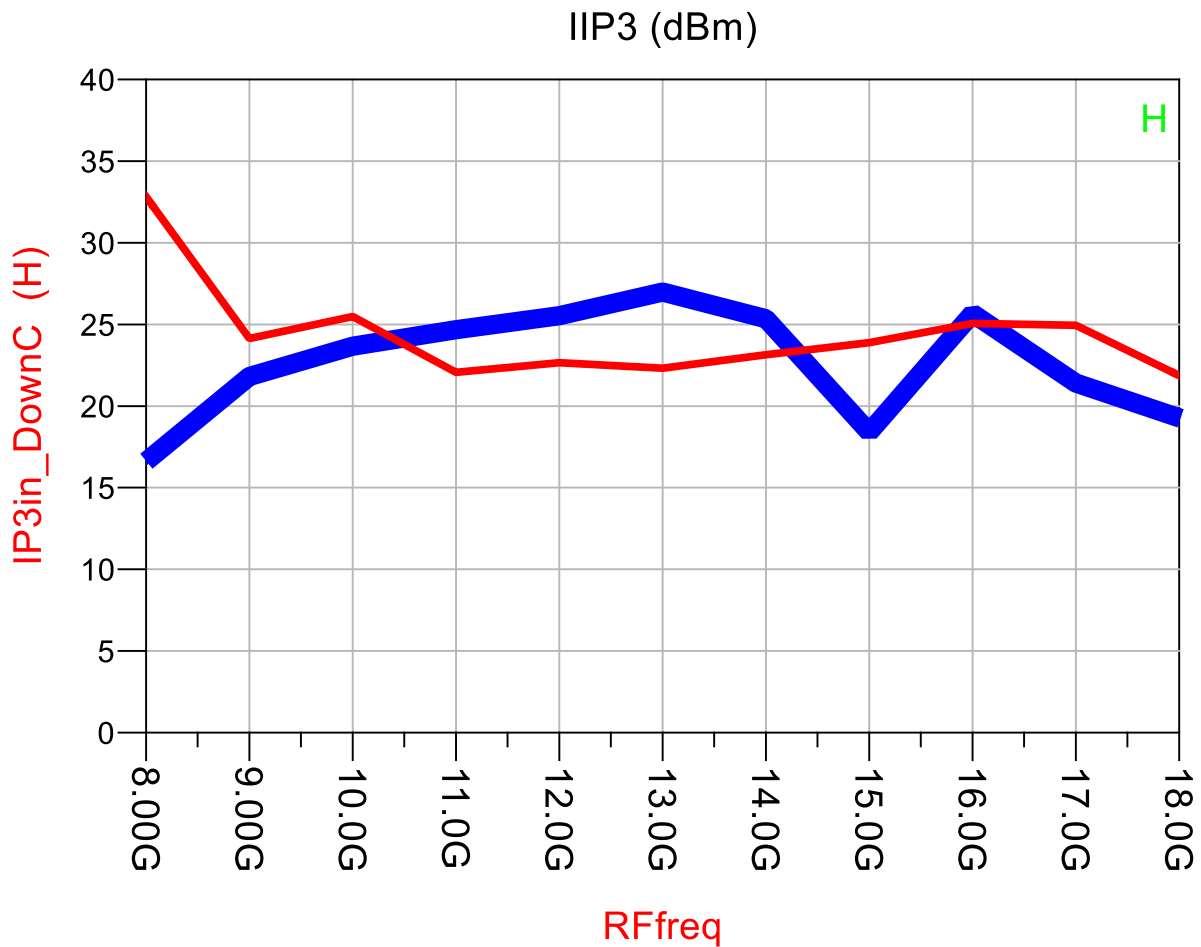

Figure 13: Comparison of IP3 (input referred) with RF input frequency

The isolation of the LO input signal to the IF output port is compared in Figure 14. Here the QRM is better, although the Star mixer performance is still respectable at ≥ 30 dB. The superior LO to IF isolation of the QRM is due to the physical separation of the LO balun from the RF/IF centre-tapped balun (see Figure 8).

The isolation of the RF input signal to the IF output signal is simulated in Figure 15. The QRM performance here is very poor. This is mainly due to the capacitor used to provide the RF short at the centre-tapped Marchand balun, shown in Figure 6. The capacitance needs to provide a good RF short circuit over the 6 to 20 GHz range. However, this means that as the IF frequency approaches 6GHz it will also see a low impedance path to ground. A compromise value of capacitance must therefore be selected, which limits the RF to IF isolation that can be obtained. One possible solution to this issue is to provide additional low-pass filtering at the IF output port to eliminate RF (and LO) breakthrough but this occupies die area and adds insertion loss. The beauty of the Star mixer is that this is not required – the IF port of the star mixer is a virtual earth and is inherently RF grounded without any associated low impedance path for the IF.

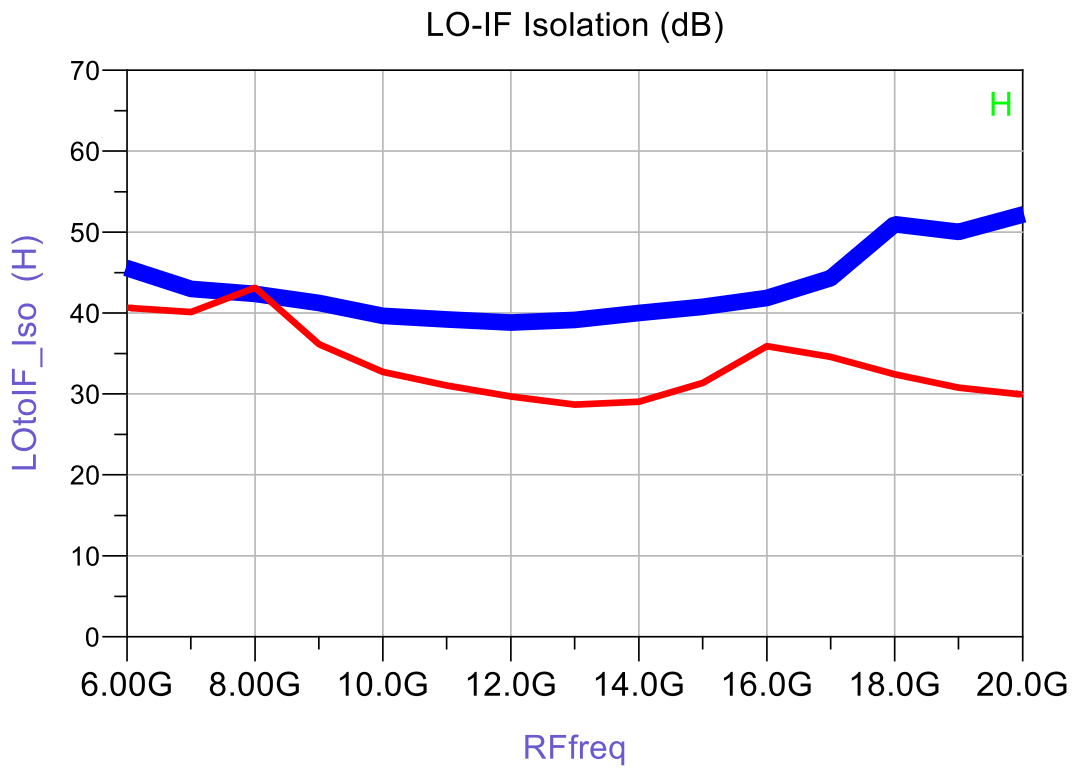

Figure 14: Comparison of LO-to-IF Isolation with RF input frequency

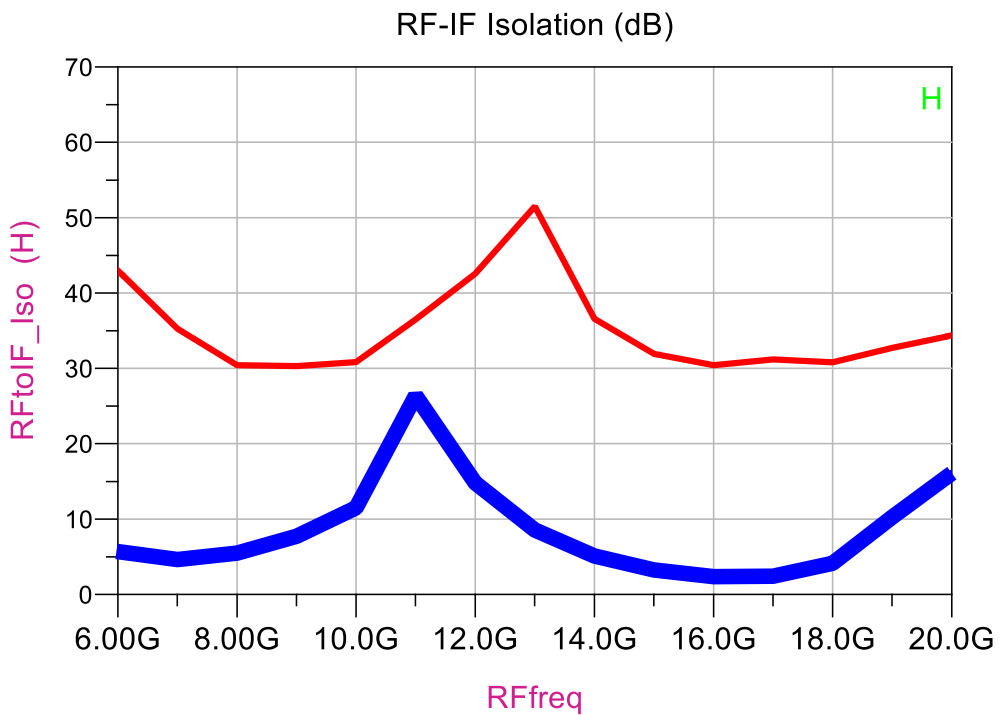

Figure 15: Comparison of RF-to-IF Isolation with RF input frequency

Conclusions

This paper has compared simulations of a previously fabricated double-balanced QRM to those of an equivalent Star mixer. The advantages of the Star mixer are greater IF bandwidth, lower conversion loss and much improved RF to IF isolation. These performance advantages are primarily due to the lower IF parasitics of the star topology. The main disadvantage of the Star configuration is that the bandwidth is limited to approximately one octave, whereas the equivalent QRM design can provide an RF bandwidth of some 3.6:1

References

- [1] S. A. Maas, *Microwave Mixers*, Artech House Antennas and Propagation Library, 1993
- [2] J. R. Long, *Monolithic Transformers for Silicon RF IC Design*, IEEE Journal of Solid-State Circuits, Vol. 35, No. 9, Sept. 2000
- [3] T. Baras, J. Mueller and A. F. Jacob, *K-Band LTCC Star Mixer With Broadband IF Output Network*, IEEE Trans. On MTT, Vol. 55, No. 12, Dec. 2007
- [4] A. W. Dearn, *MMIC Mixer Design and Simulation using Keysight ADS*,
<https://www.youtube.com/watch?v=DfOESf50tnY>
- [5] N. Marchand, "Transmission Line Conversion Transformers", *Electronics*, Vol. 17, December 1944, pp. 142-145.
- [6] A. W. Dearn, *MMIC Planar Spiral Balun Design using Keysight ADS*,
<https://www.youtube.com/watch?v=rPTjrR7D9j0>
- [7] Sun-Sook Kim, Jong-Hwan Lee and Kyung-Whan Yeom, *Design of a Novel Balun for a Star Configuration Double-balanced Mixer at S-band*,
<https://www.microwavejournal.com/articles/1677-design-of-a-novel-balun-for-a-star-configuration-double-balanced-mixer-at-s-band>, May 2004