

CORRECTED NOISE FIGURE: TOPICS IN SYSTEM INTEGRATION AND UNCERTAINTY

Jon Martens
Anritsu Company
490 Jarvis Drive
Morgan Hill, CA 95037 US

ABSTRACT

As performance requirements increase in newer communications systems, so do the measurement requirements of noise figure and other system-critical parameters. Various corrections/alternative measurement protocols are possible to enhance noise figure measurement performance beyond that available from the traditional second stage correction for the noise receiver. Among these are a class of corrections that are S-parameter related. These corrections, which are not new, generally revolve around the reality that the system, the device under test, and the networks connected to the DUT are not perfectly matched. These measurement issues will be analyzed in terms of when they will be beneficial, issues in executing the measurement, and effects on measurement uncertainty.

INTRODUCTION

For many decades, noise figure measurements have typically been carried out with a switchable noise source (two states) and a fairly wideband, high gain, tunable receiver. For almost as many years, some limitations to this measurement have been observed. This paper will focus only on a few of the uncertainty causes:

Instrumentation uncertainty (specifically gain uncertainty)
Match-induced uncertainty
Composite excess noise ratio (ENR) uncertainty

It depends greatly on the particular measurement situation which of these (if any) will be the dominant cause of uncertainty but it may be useful to expand the toolbox of techniques to minimize all of them. As an example, many of the match and gain-related corrections are of little value in the case of a very well-matched DUT (<-20 dB) but they are quite relevant when measuring many practical, high performance circuits.

Methods of correcting for these effects have been around for a long time (for a very few examples, see [1]-[8]) but it has traditionally been left to the individual experimenter to implement them in a semi-custom fashion. As instrumentation tends to a more integrated state, it is perhaps time to revisit some of these issues and how they can affect a modern measurement practice. The discussion will be fairly general with regards to the instrumentation employed since the issues to be explored are somewhat universal. It has been attempted to avoid making assumptions about the DUT, but at times, in order to simplify the discussion, amplifier-like qualities (e.g., nearly unilateral) have been assumed and are so noted.

S-PARAMETER RELATED ISSUES

This category actually includes three separate corrections but all require the measurement of the S-parameters of the DUT and/or parts of the measurement system. As such, they are all quite amenable to inclusion in a network analyzer-type measurement tool. The different subclasses will be handled in turn. Recurring themes will be the implicit assumption of good match and the requirement of performing ancillary measurement in the appropriate domain.

Gain, gain and more gain

As is well-known, the gain of the DUT figures prominently in the second stage correction equation [7]. As such, the measurement accuracy of that gain can be important--- MAINLY IF THAT GAIN IS NOT LARGE. What is sometimes less obvious, although it has been known for many years (e.g., [9]), is that the definition of the gain used can be quite critical. Since the differences may be subtle, it is important to precisely define the power gains that are involved in a typical measurement situation:

- $|S_{21}|^2$ The 'gain' one reads on a calibrated VNA. This gain makes no assumption about DUT match but assumes the ports are at 50Ω (or Z_0 in general). The VNA 12-term (or other appropriate model) calibration ensures the ports are equivalently at 50Ω .
- G_i Insertion gain is derived by normalizing with a thru line and then inserting the DUT. The Implicit assumption is that the port impedances (whatever they are) are the same during calibration and measurement. This gain definition will become increasingly different from the others as port match and/or DUT match degrade. This gain can be acquired in a scalar fashion (hence its popularity) or via a trivial calibration in a VNA.
- G_a Available gain. This gain is defined as the power available from the DUT output divided by the power available from the source [10]. It is thus making conjugate matching assumptions as appropriate. It differs most from $|S_{21}|^2$ as the DUT match degrades and will almost always be larger than $|S_{21}|^2$ (unless the source match is unusual). It may be greater or less than insertion gain but will tend to be greater if the DUT match is extremely poor.

A typical noise figure tool will use insertion gain (G_i) since it can be easily extracted from noise data acquired during the cal (thru line effectively) and during the measurement:

- Measure hot and cold power with thru line in place (which are needed to compute raw NF anyway)
- Measure hot and cold power with DUT in place
- Compute $G_i = (P_{hot,dut} - P_{cold,dut}) / (P_{hot,thru} - P_{cold,thru})$

There are some additional implementation issues in that the basic dynamic range of typical analog noise receiver is not very large. Gain ranging steps must be invoked and the gain change of those steps must be accurately known (and used to modify the above gain equation). This usually results in a higher fundamental gain uncertainty than gains acquired by VNA techniques.

Available gain, however, is the gain that is required for use in the second stage correction. While the derivations have been published many times elsewhere (e.g., [2]), the critical concept is that the thermal noise power from an ohmic source (kTB) or an equivalent noise source is an AVAILABLE power. This is not to say that the DUT would be conjugate-matched in practice, but the available gain is a requirement for the equation.

What types of errors can be introduced if one chooses the inappropriate gain? The first step is to look at how different the gain definitions are as a function of match. The most relevant ratio is G_a/G_i and is plotted as a function of the match of the DUT in Fig. 1. The instrument port matches are assumed to be -15 dB as is reasonable with most modern instrumentation and, for simplicity, the DUT is assumed to be unilateral.

The actual value of this ratio will be dependent on the relative phasing of the various match components. The curves shown in Fig. 1 illustrate the upper and lower limits of this ratio and show that available gain can be greater or less than insertion gain although it will always be larger for a sufficiently poor match.

$$\frac{G_a}{G_i} = \frac{1 - |\Gamma_s|^2}{1 - |\Gamma_{OUT}|^2} \frac{|1 - \Gamma_L \Gamma_{OUT}|^2}{|1 - \Gamma_L \Gamma_s|^2} \quad (1)$$

where

$$\Gamma_{OUT} = S_{22} + \frac{S_{12} S_{21} \Gamma_s}{1 - S_{11} \Gamma_s} \quad (2)$$

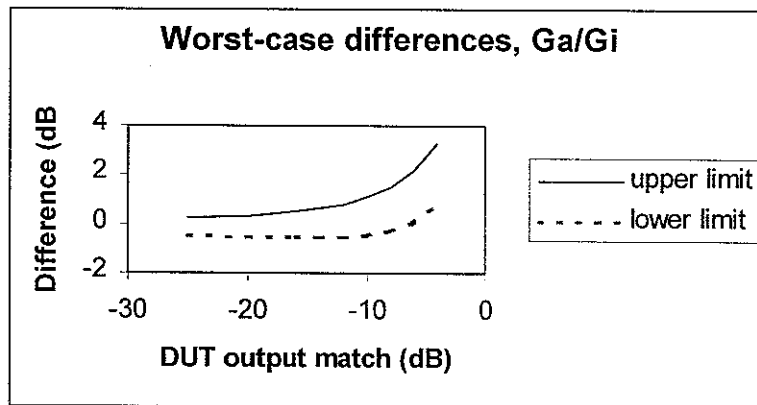

Figure 1. A plot of the ratio of available gain to insertion gain is shown here as a function of DUT match. The curves express the maximum and minimum values of this ratio as the relative phases vary.

One may also ask how insertion gain and $|S_{21}|^2$ compare since those terms are often thought of interchangeably. It is assumed the source has a -20 dB match (as might be the case for a noise source) and the receiver has a -15 dB match (which is better than specification for a number of commercial noise receivers). For simplicity the DUT is assumed to be symmetric and unilateral. The ratio of insertion gain to $|S_{21}|^2$ is shown in Fig. 2 and even these two can be significantly different.

$$\frac{G_i}{|S_{21}|^2} = \frac{|1 - \Gamma_L \Gamma_S|^2}{|1 - \Gamma_S S_{11}|^2 |1 - \Gamma_L \Gamma_{OUT}|^2} \quad (3)$$

As before, the exact value of the ratio will be dependent on the precise phase relationships involved and the figure illustrates the maximum and minimum values possible. Even for a -10 dB match, which is not unusual with many common amplifiers, the difference can exceed 1 dB. The reader may be aware that this is the argument used to justify traditional VNA calibrations over scalar measurements of gain.

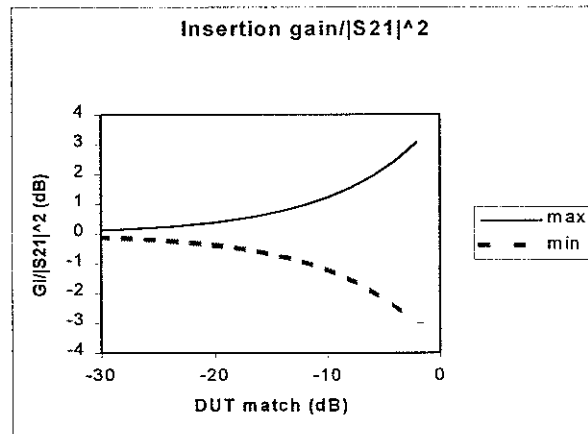

Figure 2. The ratio of insertion gain to $|S_{21}|^2$ is plotted here as a function of DUT match (assumed symmetric for simplicity). Again the curves show the maximum and minimum values of this ratio as the relative phases vary.

Noise power coupling

The second subcategory of corrections to consider is that involved in the noise coupling itself. During the noise figure measurement, the receiver measures power while the noise source is in both the hot and cold states and uses these values, together with the calibrated ENR of the noise source, to compute noise figure. If the power from the noise source couples differently in the two states, the ENR value as it is used will be in error. This implicit assumption of equal coupling requires, among other things, that the match of the noise source be the same in the two states. Unfortunately this does not entirely happen in practice; the match for a typical commercial noise source is shown in Fig. 3. While the match is reasonably good at these frequencies, the vector difference is not particularly small (and it tends to get much worse at microwave frequencies).

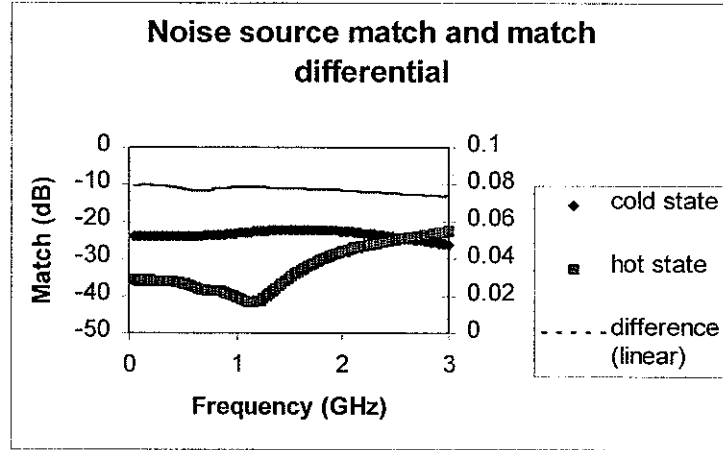

Figure 3. The output match of a commercial noise source is plotted here (both states) along with the vector difference of these matches (upper curve plotted in linear terms against the right axis). The difference is fairly substantial.

Thus even though the noise source easily meets its specifications and, in a raw sense, would be considered to be well-matched, it has a fairly severe discrepancy between hot and cold states in a vector sense.

This difference is quite important in that it directly affects the excess noise ratio delivered to the DUT. As such, it has first order impact on Y-factor and is not a secondary effect in the second stage correction equations as was the G_a - G_i issue. The effect is less onerous, however, because most common noise sources do not have too high a differential. As the DUT match worsens, however, even the better noise sources may have an associated elevation of uncertainty. Among many other reasons, this is why one often wants a heavily padded noise source when measuring bare FETs whose input match can be extremely poor.

To evaluate the correction, consider the computation of Y-factor of the receiver, which can be interpreted as the ratio of hot power delivered to the receiver to the cold power delivered to the receiver. Since the power available from the noise source is defined by kT_eB , the power delivered to the receiver in the two states can be defined by (e.g., [10])

$$P_{delivered,X} = \frac{kT_X B(1-|\Gamma_L|^2)(1-|\Gamma_{SX}|^2)}{|1-\Gamma_L\Gamma_{SX}|^2} \quad (4)$$

Where X represents either the H (hot) or C (cold) state. Thus the Y factor measured is actually

$$Y_{measured} = \frac{T_H(1-|\Gamma_{SH}|^2)|1-\Gamma_L\Gamma_{SC}|^2}{T_C(1-|\Gamma_{SC}|^2)|1-\Gamma_L\Gamma_{SH}|^2} = Y \frac{(1-|\Gamma_{SH}|^2)|1-\Gamma_L\Gamma_{SC}|^2}{(1-|\Gamma_{SC}|^2)|1-\Gamma_L\Gamma_{SH}|^2} \quad (5)$$

One can then define a correction factor

$$MX_{cal} = \frac{(1 - |\Gamma_{sc}|^2) |1 - \Gamma_L \Gamma_{sh}|^2}{(1 - |\Gamma_{sh}|^2) |1 - \Gamma_L \Gamma_{sc}|^2} \quad (6)$$

Similarly when measuring the DUT,

$$MX_{dut} = \frac{(1 - |\Gamma_{sc}|^2) (1 - S_{11} \Gamma_{sh}) (1 - S_{22} \Gamma_L) - S_{12} S_{21} \Gamma_{sh} \Gamma_L}{(1 - |\Gamma_{sh}|^2) (1 - S_{11} \Gamma_{sc}) (1 - S_{22} \Gamma_L) - S_{12} S_{21} \Gamma_{sc} \Gamma_L} \quad (7)$$

As an example of this mechanism, consider a DUT whose gain is high enough that the G_a - G_i issue has a relatively small effect. The result with and without the correction applied is shown in Fig. 4. The spans in frequency of the greatest discrepancy correspond to the spans of the poorest match as might be expected.

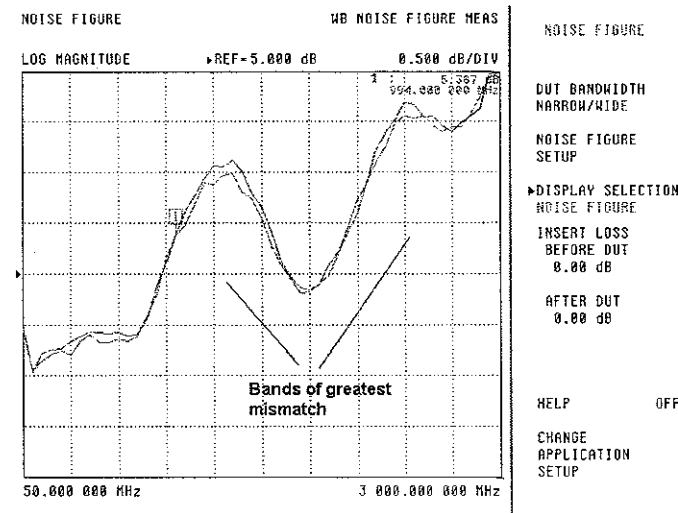

Figure 4. The noise figure of an amplifier with and without vector correction is plotted here. The gain is sufficiently high that gain errors should have a small effect on the result leaving a noise coupling effect as dominant. The greatest discrepancy is observed where the DUT has the greatest mismatch.

The match differential in this case is not enormous (.03-.04 linear) and the DUT match is about -8 dB so the effects are not huge but they are measurable. In the case of extremely poorly matched DUTs, the difference can of course become much larger.

The effects of external networks (cables, fixtures, ...)

A third subcategory is that of handling networks before and after the DUT. The subject of networks after the DUT will be skipped here since it is a second stage effect and common algorithms treating that network as a pad can work reasonably well (assuming the DUT gain is relatively large and well-defined). The one

important caveat is that these networks usually have some frequency response and a single loss value cannot be used across all frequencies.

Of considerably more interest may be networks before the DUT. Since this network can be thought of as the first stage (usually with loss), its importance can obviously be great in the sense of the second stage correction equation. Another approach is to think of this network as modifying the ENR being applied to the DUT. Since this is a first order effect on Y-factor, the accuracy of characterizing that network is clearly of critical importance (e.g., [11]).

Historically, this network has been treated much like a pad (loss before DUT, loss after DUT) and entered as a single insertion loss value (which presumably the user will update manually for each different test frequency). The penalties for ignoring the frequency response when making broadband measurements can be severe as shown in Fig. 5. On a DUT with significant gain, errors in assessing this loss will fall straight through to noise figure error on dB-for-dB basis. Thus in this example if one were to use a single loss value for the whole frequency range, the noise figure error could exceed 1 dB.

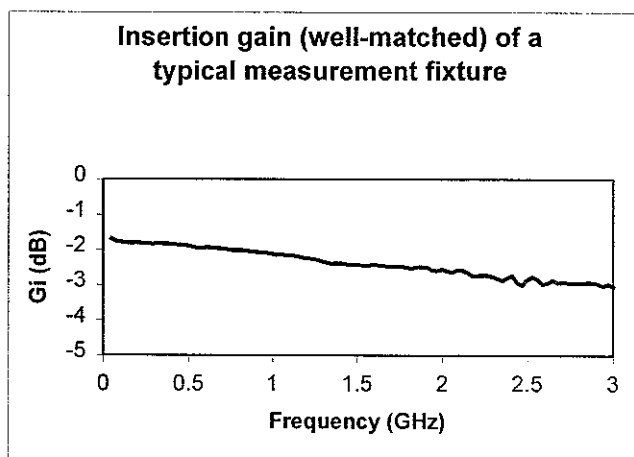

Figure 5. The insertion loss of a typical measurement fixture that may be between the noise source and the DUT is shown here. The frequency response must be taken into account on a broadband measurement.

The next question revolves around the importance of match. Treating the original noise source plus network as the new effective noise source, the important question is what is the available noise power from this new source (basic to the definition of ENR). Again the concept of available gain is important; the power available from the composite network will be related to the ENR (~power available from the noise source) and the available gain of that network. Thus once again, match becomes a critical parameter.

The simplest way to test these effects is to measure the noise figure of the DUT without such a network in place, then insert the network and apply the correction. If the correction is ideal, the two results would be identical. In the first example, an amplifier is tested with and without a network with about 3 dB of loss and about -12 dB input and output match. The full vector correction for this network is applied and the results agree to within about 0.08 dB (that residual is probably due to connector repeatability and amplifier thermal drift).

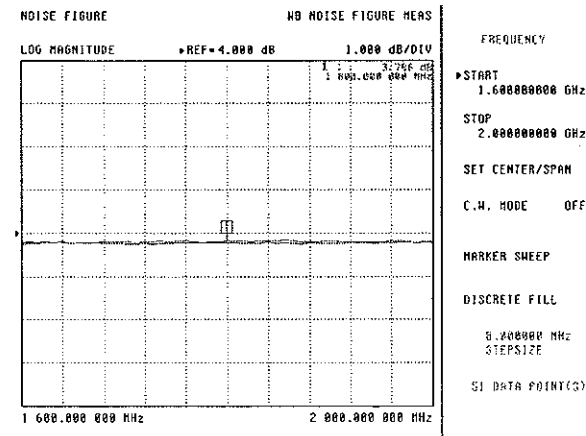

Figure 6. The noise figure of an amplifier without an input network and with an input network (~ 3 dB of loss) and correction applied are shown here. The network's S-parameters were fully characterized and used to compute an ENR correction.

In the second example, a simple loss before DUT correction is applied. Since the frequency range is quite small and the network's loss is very flat (to better than 0.05 dB in this range), it is not the frequency response of the network that affects the results. Rather it would appear that the use of a simple insertion loss of this network causes up to 0.2 dB of error. The match of this network is on the order of -10 dB.

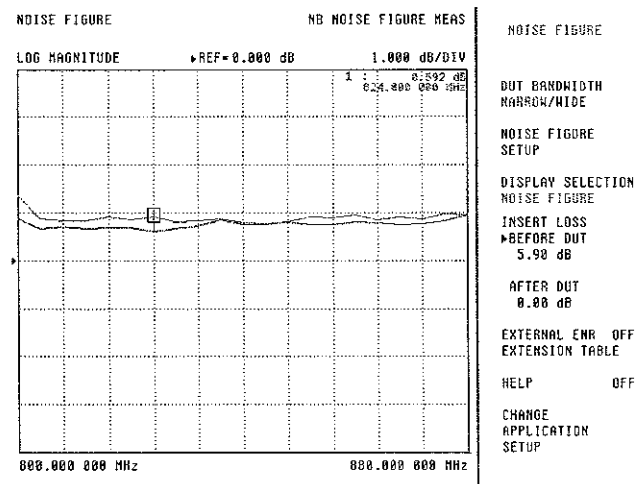

Figure 7. The noise figure of an amplifier without an input network and with an input network and scalar correction applied are shown here. The simple loss-before-DUT correction suffers from lower raw accuracy and neglects match effects, which tend to increase the measurement uncertainty.

IMPLEMENTATION

While all of these corrections are quite justifiable and all have a benefit to measurement uncertainty, there are a large number of practical issues related to the integration of these factors. The most obvious of which is that S-parameter acquisition must be integrated with noise data acquisition on at least a sweep-by-sweep basis. While the noise figure measurement is somewhat slow, if any attempt at tuning is to be performed, the two measurement types must occur roughly simultaneously. Even in the case of no tuning, it is important in case the DUT is drifting in time that the measurements be performed as simultaneously as possible. With highly repeatable PIN and FET switches, this does not present much of a measurement issue (at least at rf frequencies). A block diagram of one switching arrangement is shown in Fig. 8.

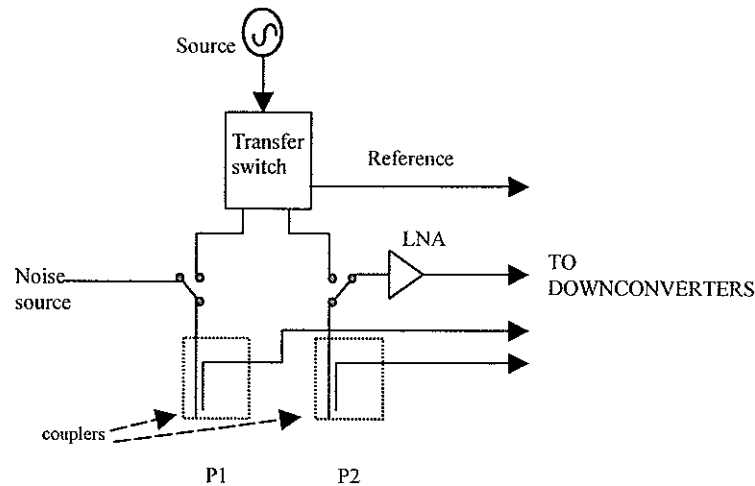

Figure 8. One implementation in which noise figure measurements and S-parameters can be acquired with a single connection of the DUT is shown here. It is important to accurately characterize the path between the noise source and P1 as well as minimize the loss between P2 and the LNA.

As mentioned in the previous section, the S-parameters of the path between the noise source and the port can be characterized at the factory or by the user (on a non-routine basis) and used to calculate an effective ENR at the port. In many cases, a user test fixture or cabling arrangement will be appended to the port. If the S-parameters of this network are measured, they can be appended to those of the internal network using a standard transmission matrix algorithm [10]. This can be termed a combination of internal and external ENR extension tables for maximum confusion. If one defines an S-parameter matrix S^A to be those parameters describing the internal routing network and S^B to be the matrix describing the additional external network, then the composite network is given by

$$[S^{comp}] = \frac{1}{1 - S_{22}^A S_{11}^B} \begin{bmatrix} S_{11}^A - \Delta^A S_{11}^B & \frac{\Delta^B \Delta^A + S_{11}^A S_{22}^A S_{11}^B S_{22}^B - S_{11}^A S_{22}^A \Delta^B - S_{11}^B S_{22}^B \Delta^A}{S_{21}^A S_{21}^B} \\ S_{21}^A S_{21}^B & S_{22}^B - \Delta^B S_{22}^A \end{bmatrix} \quad (8)$$

Where the Δ s represent the determinants of the base matrices. From this composite set of S-parameters, an available gain can be calculated as usual and, from that, the effective ENR presented to the DUT can be computed.

Clearly, the S-parameter measurements must also be made in tandem with the noise figure calibration as well. This way the load match (i.e., receiver) as well as the source match (in both hot and cold states) can be measured.

One issue that is important but easy to overlook is that of the power level used during the S-parameter measurements. Since the noise measurement is assumed to occur in a small signal realm (some danger on this as well if DUT gain exceeds 50 dB, power integrated over the total noise bandwidth is relevant), the corresponding S-parameter measurement must also be small signal in nature. While this is obvious, the magnitudes of errors can be enormous if not followed. Below is a power sweep of a low noise amplifier with admittedly a very low compression point. The recommended small signal input level for this amplifier is -35 dBm. The corrected noise figure for this amplifier with S-parameters acquired at a proper power level is shown in Fig. 9 as well as when an S-parameter drive level of -10 dBm was used.

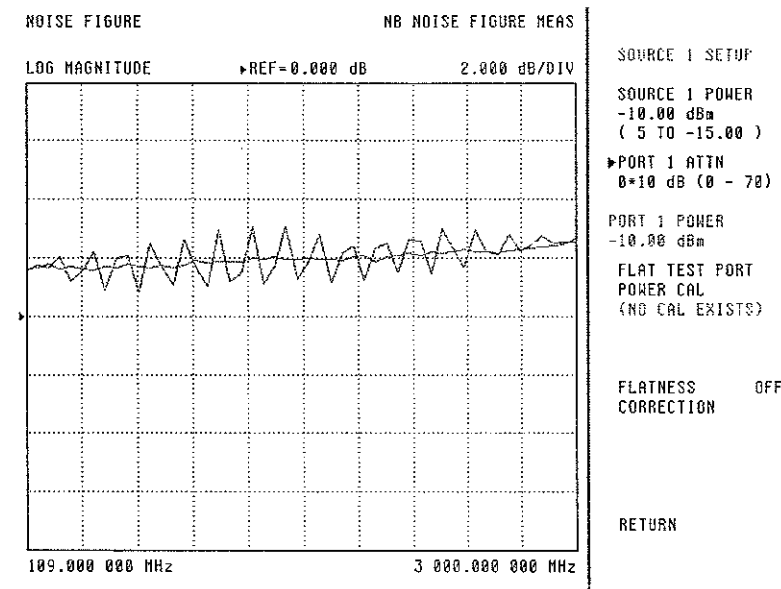

Figure 9. The corrected noise figure of an amplifier when the S-parameter data is acquired at a reasonable power level (-35 dBm) versus a higher level (-10 dBm) which is compressing the DUT. Since the higher level represents a different state for the amplifier than when noise data is collected, the results will be erroneous.

Since the available gain (and match values for noise coupling computations) is acquired with the DUT in a different state from when noise measurements were being made (partially compressed vs. linear), one cannot expect the corrections to make sense. In this particular case, the input match of the DUT is quite poor with -10 dBm incident and the ripple in that S11 measurement maps straight onto the final result since there is no real effect to correct.

UNCERTAINTIES

There are an extremely large number of variables affecting noise figure measurement uncertainty and almost as many methods for analyzing them (e.g., [6], [12], [13]). In this paper, the prime interest is to look at the effects of some of the corrections on measurement uncertainty so the analysis approach will be somewhat tailored. Environmental, repeatability, and spurious effects will not be considered. The model will include uncertainties in Y-factor, gain, those due to match, ENR and instrumentation. A modified root-sum-of-squares (RSS) calculation approach will be used as detailed elsewhere [12].

An example uncertainty curve is shown in Fig. 10 so that a few key points can be explained. The receiver noise figure is used as a plotting parameter and is generally set by the instrumentation and/or fixturing. The match of the DUT is labeled at the top of the graph and the value is assumed to apply to both DUT ports. All graphs used here will apply to a wideband measurement algorithm (WBNF) which is typical of most analog measurement protocols. One typical measurement regime is that of an amplifier with reasonable gain or a network of modest gain and relatively high noise figure. Both of these cases fall into the asymptote of the curves at the far right of the diagram. This is the location of minimum uncertainty (where receiver noise figure and DUT gain have almost no impact) and is dominated by ENR uncertainty, instrumentation uncertainty and match effects.

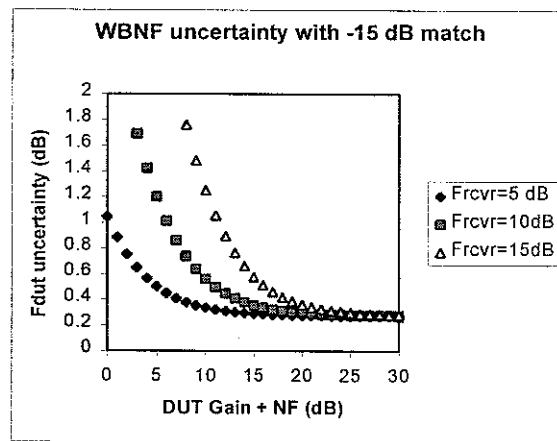

Figure 10. An example uncertainty curve set for wideband noise figure measurements at a DUT match of -15 dB is shown in this figure. Most amplifier measurements will reside in the asymptote of the curves at the right side.

At the opposite extreme is a passive device whose gain+NF may be close to 0 dB placing the uncertainty at the far left of the diagram. This is the region of maximum uncertainty where receiver NF and gain accuracy play a critical role. The uncertainty in this regime can be reduced by decreasing the receiver noise figure which can be done, for example, by placing a low noise amplifier in front of the receiver.

Consider the following issues:

- Gain uncertainty
Traditional NF uncertainty analysis ignores the error in using insertion gain. Even aside from that difference, the uncertainty in an S-parameter derived gain measurement will usually be much less than that derived from noise data for reasons detailed earlier.
- Match uncertainty
With the incorporation of S-parameter data the uncertainty in the amount of power coupled in the various noise states can be greatly reduced. Fairly conservative estimates of uncertainty in the match measurements were used.
- ENR uncertainty
When external networks are employed, the resultant composite ENR uncertainty may often dominate the measurement and this is often ignored in conventional uncertainty analysis.

The first set of uncertainty curves compare corrected to uncorrected wideband measurements. The changes reflect only the effects of reduced gain measurement uncertainty and a reduction in match effects. The corrected measurements include some effective ENR uncertainty due to the addition of a routing network but that uncertainty is reduced from the worst possible by virtue of the S-parameter based calculation. The WCAC8 model (worst case angle combination) referenced in the graph refers to assumptions about the S-parameter measurement uncertainties and how they are allowed to combine.

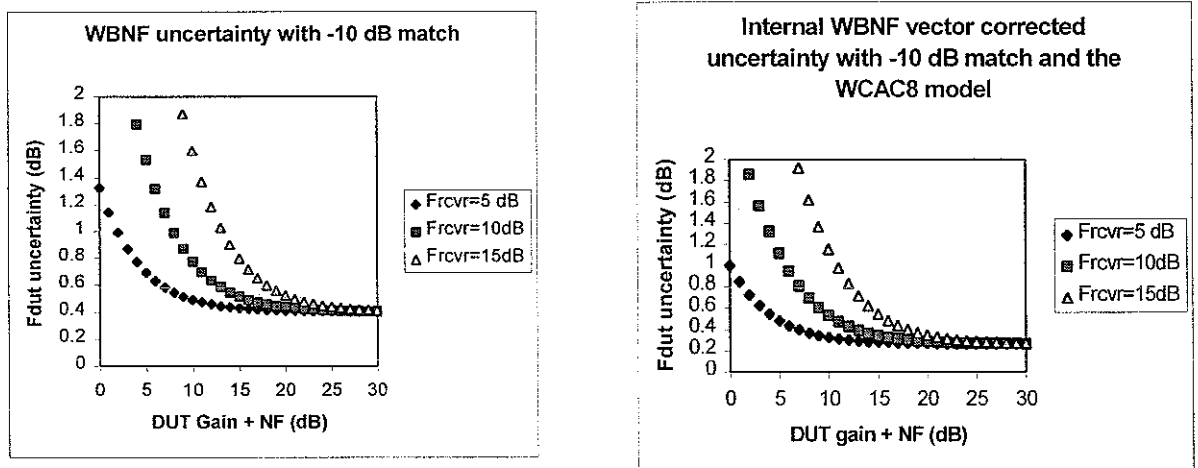

Figure 11. Uncertainty curves for wideband noise figure measurements, with and without the corrections discussed in this document, are shown here. The effects are confined to gain measurement accuracy and match-related noise coupling effects only.

In the asymptote of a high gain + NF DUT, one can consider the following improvements due to the changes discussed above: a reduction from about 0.41 dB to about 0.25 dB. The residual is largely the base uncertainty in ENR (about 0.1 dB) and the instrumentation (0.1-0.15 dB) plus some component due to uncertainty in the S-parameters themselves. For lower gain devices, the improvement is more substantial largely due to the criticality of accurate gain measurements in that regime.

In reality, the improvement is more substantial than indicated since the uncorrected uncertainty curves do not include contributions from the error in gain definition (G_s vs. G_i) only in gain measurement uncertainty.

Next consider the problem of a user-added test fixture. In the uncorrected fashion, it is assumed that a loss-before-DUT model is used while in the corrected version, a full S-parameter correction is employed. The network is assumed to have an input and output match of -15 dB which is certainly achievable in many circumstances but is optimistic for many wafer probing scenarios. Assume that the DUT gain is sufficiently high that the measurement will be in the asymptote of the uncertainty curves and that the DUT match is -10 dB.

Network match: -15 dB

Uncorrected uncertainty: ENR uncertainty will increase substantially due to scalar gain uncertainty and match-induced power transfer error; composite value balloons to about 0.5 dB

Corrected uncertainty: ENR uncertainty will increase, in an RSS sense, with uncertainty in network gain computation, composite increases to about 0.28 dB

The levels of uncertainty here may be surprising but it is important to remember that any errors in effective ENR will fall straight to the bottom line of noise figure uncertainty in the case of an asymptotic device. Characterizing the input networks accurately is obviously of paramount importance.

CONCLUSIONS

Several of the known S-parameter related corrections for noise figure have been reviewed in some detail. Included in this analysis has been a look at regimes of applicability, some implementation issues and how these corrections can affect composite uncertainty. Among some of the key findings are

- Gain definition and measurement accuracy are of prime importance in lower gain devices (<10 dB typically, possibly <15 dB if the noise figure is very low)
- Noise coupling issues are always important but can be small (<0.1 dB uncertainty effect) if the noise source has a small match differential)
- The characterization of any network (cables, fixtures,...) at the DUT input is extremely critical as any errors feed straight to noise figure error.

While there are many other potential corrections that can be applied, space dictated that not all could be covered in this document. Among other issues are measurement bandwidth when the DUT is heavily bandlimited (e.g., measurements required just near the band edge of a filter-amplifier combination). Some corrections are available for the wideband techniques discussed here and narrowband measurement techniques are available that do not suffer from inordinate measurement time penalties (e.g., [8]).

REFERENCES

1. T. Mukaihata, B. L. Walsh, M. F. Bottjer, and E. B. Roberts, "Subtle Differences in System Noise Measurements and Calibration of Noise Standards," IRE Trans. on MTT, Nov. 1962, pp. 506-516.
2. Noise Figure Measurements, Anritsu Application Note, 1999.
3. G. Martines and M. Sannino, "The Determination of the Noise, Gain and Scattering Parameters of Microwave Transistors (HEMTs) Using Only an Automatic Noise Figure Test-Set," IEEE Trans. on MTT, vol. 42, July 1994, pp. 1105-1113.
4. E. Strid, "Noise Measurements for Low-Noise GaAs FET Amplifiers," Microwave Systems News, November 1981, pp. 62-70.
5. N. J. Kuhn, "Curing a Subtle But Significant Cause of Noise Figure Error," Microwave Journal, Vol. 27, No. 6, June 1984, pp. 85-98.
6. Fundamentals of RF and Microwave Noise Figure Measurements, Hewlett-Packard Application Note 57-1, 1983 and Noise Figure Measurement Accuracy, Hewlett-Packard Application Note 57-2, 1988.
7. H. T. Friis, "Noise Figures of Radio Receivers," Proceedings of the IRE, vol. 32, July 1944, pp. 419-422.
8. D. Vondran, "Vector Corrected Noise Figure Measurements," Micr. Journal, Mar. 1999, pp. 22-38.
9. "IRE Standards on Methods of Measuring Noise in Linear Two Ports, 1959," IRE Subcommittee on Noise, Proc. of the IRE, Jan. 1960, pp. 60-68.
10. G. Gonzalez, Microwave Transistor Amplifiers, Prentice-Hall, 1984, chp. 3.
11. S. Pak and T. Chen, "Simple System Yields On-Wafer Noise Parameters," Micr. and RF, Jul. 1990, pp. 103-108.
12. NF Accuracy, Anritsu Application Note, 1999.
13. HP Product Note 85719A-1